

ISO 9001

AV AUTOMATIC VALVE

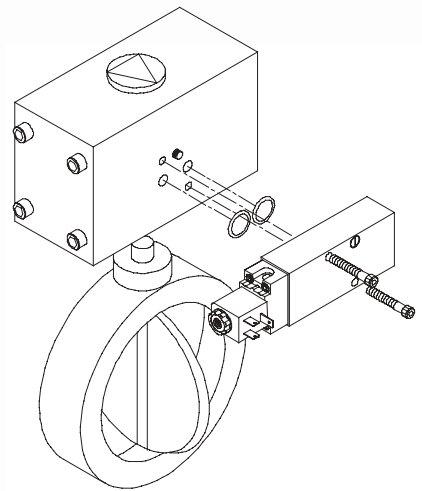
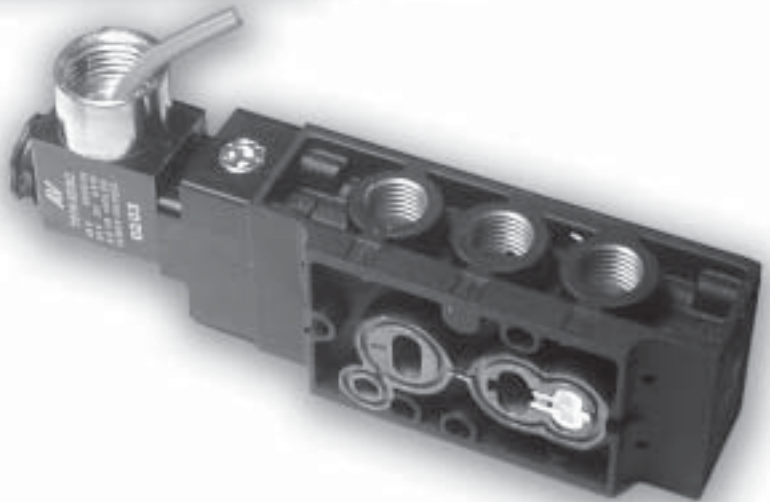

ACTUATOR MOUNT NAMUR SOLENOIDS

DESIGN FEATURES

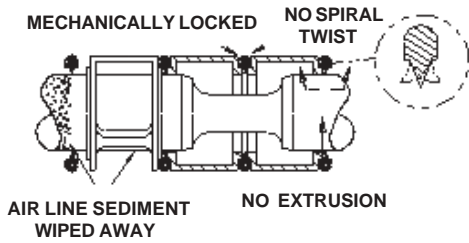

VALVES

- Proven design with 10+ years OEM experience.
- Options available to meet your requirements: Nema 7, stainless steel, fluoroelastomer seals.
- Easily converted from 4 way to 3 way operation.

TAPERED TEE-SEAL Eats Dirt

- Bi-directional tapered Tee-Seal flexes to clean spool. Eliminates Monday morning sticking problems.
- Tested tough and proven reliable according to SAE specifications: Rust and water injected every 864,000 cycles for 20 million cycles.

SOLENOID ... Guaranteed Against Burnout

- Three-way pilot uses full air line pressure to shift the valve.
- Pilot is internally supplied when the pressure at port one is 35 to 150 PSIG (240 to 1030 kPa).
- Coil is hermetically sealed as an integral watertight molded unit.
- Intrinsically-safe and explosion-proof versions available.
- Push non-locking override. (Extended turn and turn lock available)

PRODUCTS CERTIFIED TO INCLUDE

- CSA - (C22.2)
- UL - (STD 429)
- ATEX - (2018x)
- PTB - (EExmIIT5) (EExialICT6)
- CE - (73/23/EEC), (89/336/EEC)

INDEX

	Page
Design Features	B2
Specifications	B3
Model Number Chart	B3
Standard Solenoid Models Dimensional Information	B4 B5
Intrinsically-Safe Solenoid Models Dimensional Information	B6 B7
Air Pilot Models Dimensional Information	B8 B9
Options	B10/B11
Electrical Information	B12
Service Information	B13
4 way to 3 way conversion	B14

SPECIFICATIONS

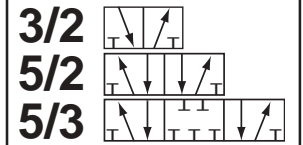

VALVE OPERATION			
 DE-ENERGIZED	 ENERGIZED	3/2 NC - 3 way 2 position normally closed valves shift and apply pressure when a maintained signal is applied to the operator then reset and block pressure when the signal is removed.	 ENERGIZED
 DE-ENERGIZED	 ENERGIZED	5/2 SINGLE - 4 way 2 position single operator valves shift, apply pressure from port 1 to 4, and exhaust pressure from port 2 to 3 when a maintained signal is applied to operator 1-4. Valves reset, apply pressure from port 1 to 2, exhaust pressure from port 4 to 5 when the signal is removed.	 ENERGIZED
 DE-ENERGIZED	 ENERGIZED	5/2 DOUBLE - 4 way 2 position double operator valves shift, apply pressure from port 1 to 4, and exhaust pressure from 2 to 3 when a momentary signal is applied to operator 1-4. Valves shift, apply pressure from port 1 to 2, and exhaust pressure from 4 to 5 when a momentary signal is applied to operator 1-2.	 ENERGIZED
OPERATING TEMPERATURES 	SOLENOID PILOT OPERATED	TREATED BUNA-N SEALS (TREATED NBR, Standard)	FLUOROELASTOMER SEALS (FPM (FKM), Option A)
	Standard High Temp Coil (Option T)	-18°C to +52°C (0°F to +125°F) -18°C to +82°C (0°F to +180°F)	-18°C to +52°C (0°F to +125°F) -18°C to +82°C (0°F to +180°F)
OPERATING PRESSURES 	SOLENOID PILOT OPERATED	INLET PORT	EXTERNAL PILOT PORT
	Standard 2 Position Standard 3 Position External Pilot (Option B)	240 - 1030 kPa (35 - 150 PSIG) 345 - 1030 kPa (50 - 150 PSIG) Vacuum - 240 kPa (Vacuum - 35 PSIG)	Not Required Not Required 240 - 1030 kPa (35 - 150 PSIG)
	FILTRATION AND LUBRICATION 	MEDIA - AIR OR INERT GAS Lubrication of Automatic Valve products is not required but is recommended to maximize service life. Oils should be compatible with seal material, have an ISO 32 viscosity, and have an aniline range of 82°C (180°F) and 99°C (210°F). Refer to Maintenance section of catalog for recommended lubricants. Filter to 50 microns or better. For temperatures below 40°F, air must be dry to prevent formation of ice.	

MODEL NUMBER CHART

SERIES	BODY TYPE	PORT SIZE	FUNCTION	BODY DESIGN	OPERATOR 1	CENTER OPERATOR	OPERATOR 2	VOLTAGE	OPTIONS
D06	0	NAMUR	3 1/4	G 3 WAY NC	A RIGHT	V INTRINSICALLY-SAFE SOLENOID W WEATHER-PROOF SOLENOID	R 2 POSITION SPRING	AA 110/50, 120/60 220/50, 240/60, 125VDC DA 22/50, 24/60 DB 12VDC, 24VDC	A FLUOROELASTOMER SEALS (D20) B EXTERNAL PILOT CONNECTION (D20) C CONDUIT COIL CT CONDUIT COIL HIGH TEMPERATURE D DUSTPROOF (D20) G 18" FLYING LEADS L LOW WATT COIL P TRANSITION PLATE (D20) Q CLOSED LOOP (D20) S STAINLESS STEEL BODY W G THREADS Y EXPLOSION-PROOF COIL (CSA, FM) Z EXPLOSION-PROOF COIL (ATEX, PTB) 1 PUSH TURN LOCKING OVERRIDE 2 EXTENDED TURN LOCKING OVERRIDE 8 10-24 MOUNTING KIT 9 10-32 MOUNTING KIT
D20			A 4 WAY 2 POSITION	A RIGHT	A AIR PILOT	D 3 POSITION SPRING	A AIR PILOT		
			C 4 WAY 3 POSITION BLOCK CENTER	B LEFT	V INTRINSICALLY-SAFE SOLENOID	R 2 POSITION SPRING	R 2 POSITION SPRING		
			D 4 WAY 3 POSITION EXHAUST CENTER		W STANDARD SOLENOID		V INTRINSICALLY-SAFE SOLENOID		
			E 4 WAY 3 POSITION PRESSURE CENTER				W STANDARD SOLENOID		
			G 3 WAY NC						

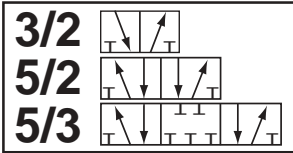

STANDARD SOLENOID MODELS

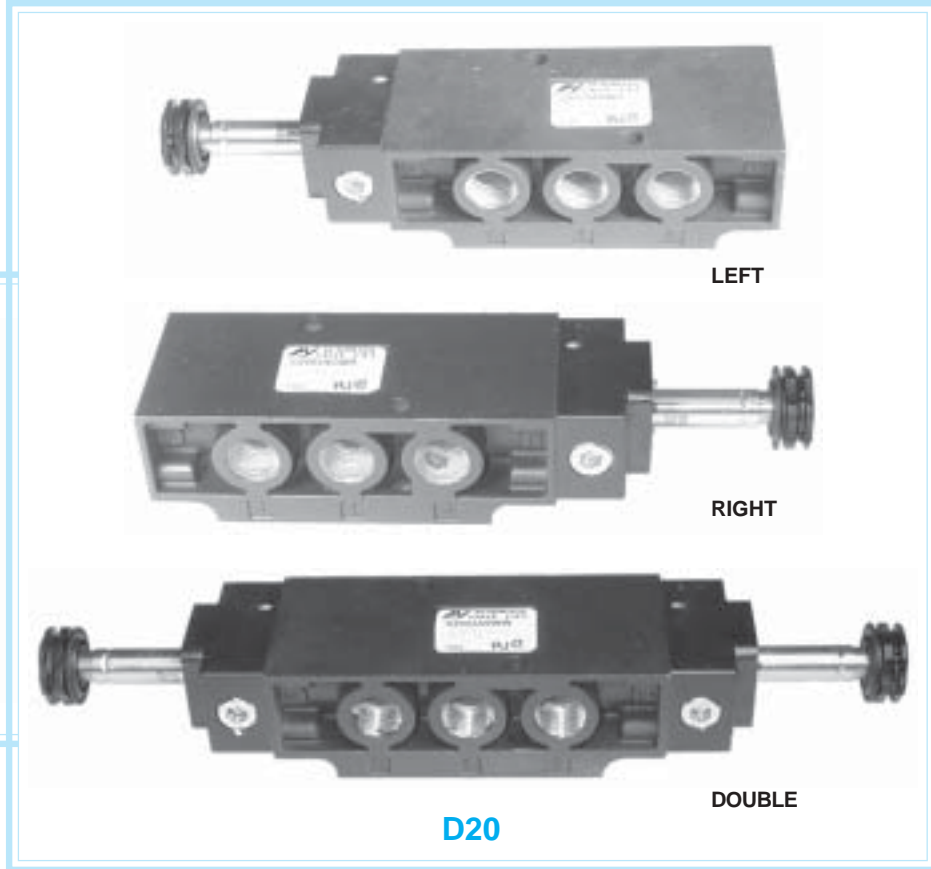

MODEL NUMBERS

FUNCTION		PORT SIZE	Cv (l/min)	MODEL NUMBER	BODY MATERIAL	SEAL MATERIAL	Kg (LB)
DESCRIPTION	SCHEMATIC						
3/2 NORMALLY CLOSED SINGLE SOLENOID		1/4	0.6 (590)	D0603GAWR*	ALUMINUM	-	0,26 (.58)
3/2 NORMALLY CLOSED SINGLE SOLENOID LEFT		1/4	1.8 (1770)	D2003GCWR*	ALUMINUM	NBR	0,32 (.70)
3/2 NORMALLY CLOSED SINGLE SOLENOID RIGHT				D2003GAWR*			
5/2 SINGLE SOLENOID LEFT		1/4	1.8 (1770)	D2003ACWR*	ALUMINUM	NBR	0,32 (.70)
5/2 SINGLE SOLENOID RIGHT				D2003AAWR*			
5/2 DOUBLE SOLENOID				D2003ABWW*			
5/3 BLOCK DOUBLE SOLENOID		1/4	1.8 (1770)	D2003CBWDW*	ALUMINUM	NBR	0,36 (.80)
5/3 EXHAUST DOUBLE SOLENOID				D2003DBWDW*			
5/3 PRESSURE DOUBLE SOLENOID				D2003EBWDW*			

*Coils sold separately. Refer to Electrical Section for additional information.

DIMENSIONAL INFORMATION

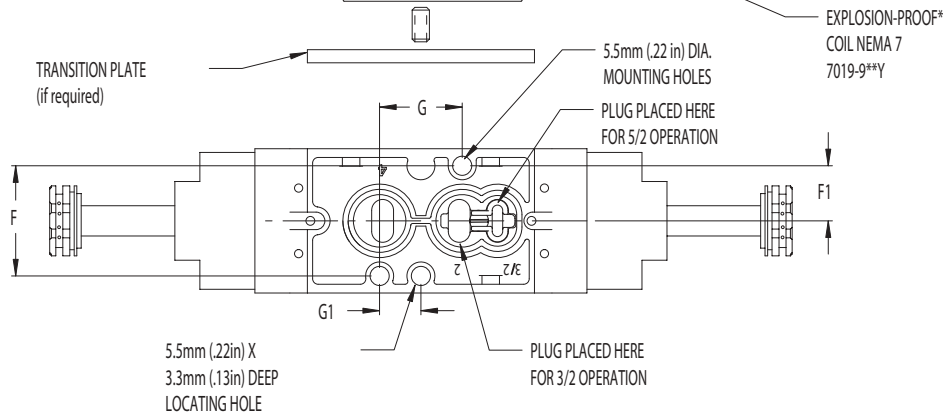
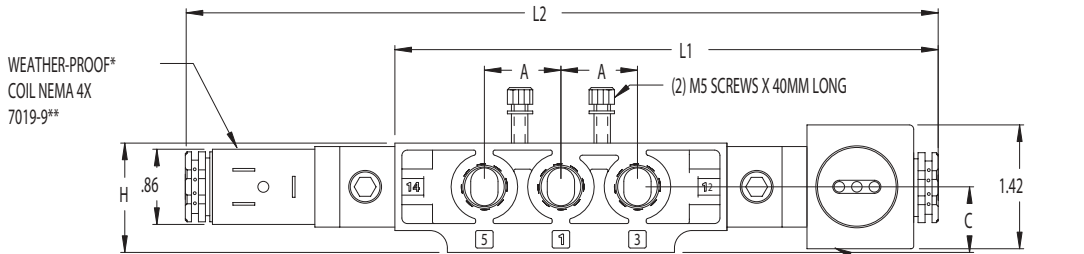
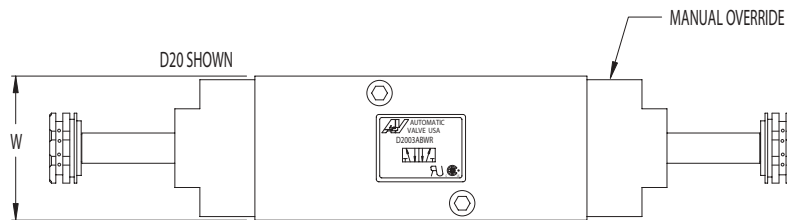
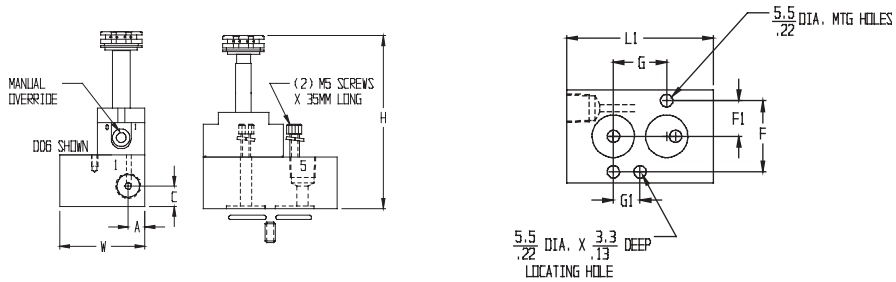
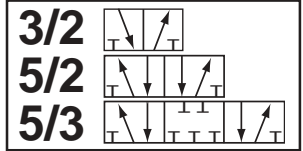

SERIES	DESCRIPTION	A	C	F	F1	G	G1	H	L1	L2	W
D06	SINGLE SOLENOID	8,4 .33	10,2 .40	32,0 1.26	16,0 .63	23,9 .94	11,9 .47	85,1 3.35	66,0 2.60	-	41,9 1.65
D20	SINGLE SOLENOID	22,2 .88	19,1 .75	32,0 1.26	16,0 .63	23,9 .94	11,9 .47	31,7 1.25	155.4 6.12	-	41,9 1.65
	DOUBLE SOLENOID	22,2 .88	19,1 .75	32,0 1.26	16,0 .63	23,9 .94	11,9 .47	31,7 1.25	-	214 8.42	41,9 1.65

Units of Measure: Top - mm, Bottom - inches

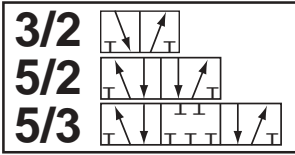

INTRINSICALLY-SAFE SOLENOID MODELS

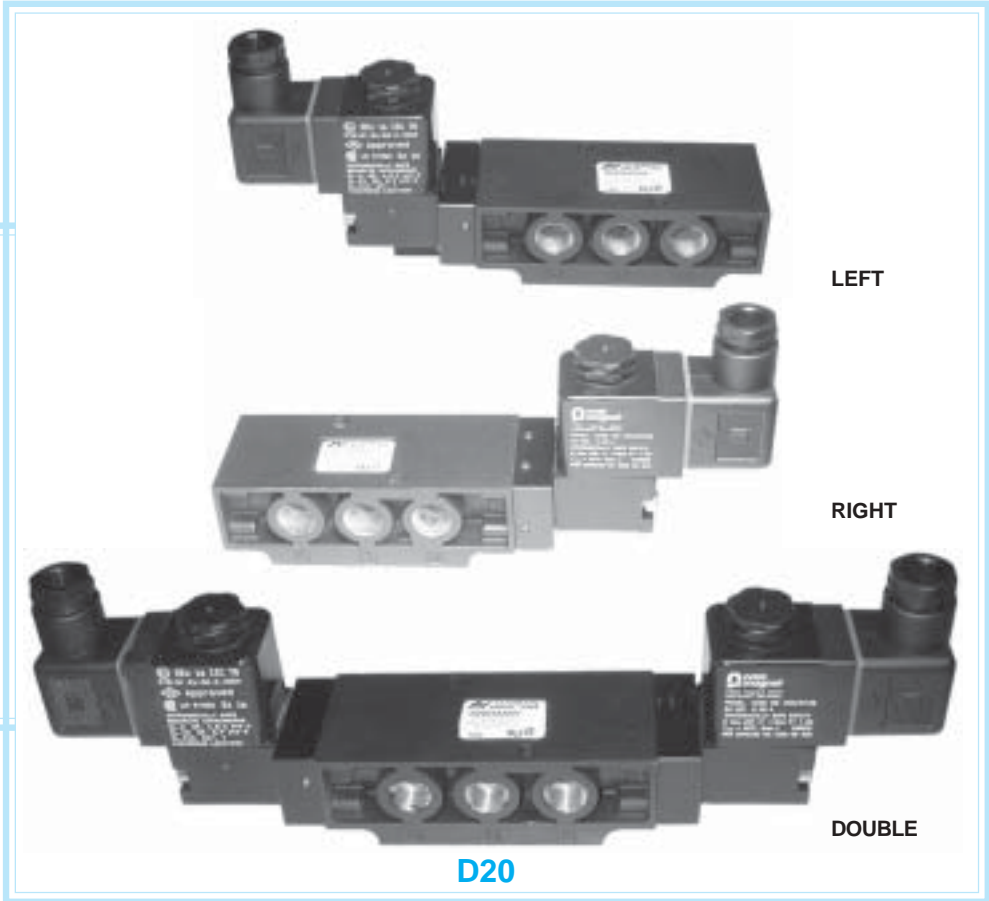

MODEL NUMBERS

FUNCTION		PORT SIZE	Cv (l/min)	MODEL NUMBER	BODY MATERIAL	SEAL MATERIAL	Kg (LB)
DESCRIPTION	SCHEMATIC						
3/2 NORMALLY CLOSED SINGLE SOLENOID RIGHT		1/4	0.06 (590)	D0603GAVR*-DB	ALUMINUM	-	0,26 (.58)
3/2 NORMALLY CLOSED SINGLE SOLENOID LEFT		1/4	1.8 (1770)	D2003GCVR*-DB	ALUMINUM	NBR	0,32 (.70)
3/2 NORMALLY CLOSED SINGLE SOLENOID RIGHT				D2003GAVR*-DB			
5/2 SINGLE SOLENOID LEFT		1/4	1.8 (1770)	D2003ACVR*-DB	ALUMINUM	NBR	0,32 (.70)
5/2 SINGLE SOLENOID RIGHT				D2003AAVR*-DB			
5/2 DOUBLE SOLENOID				D2003ABVV*-DB			
5/3 BLOCK DOUBLE SOLENOID		1/4	1.8 (1770)	D2003CBVDV*-DB	ALUMINUM	NBR	0,36 (.80)
5/3 EXHAUST DOUBLE SOLENOID				D2003DBVDV*-DB			
5/3 PRESSURE DOUBLE SOLENOID				D2003EBVDV*-DB			

*Coils included with valve. Refer to Electrical Section for additional information.

DIMENSIONAL INFORMATION

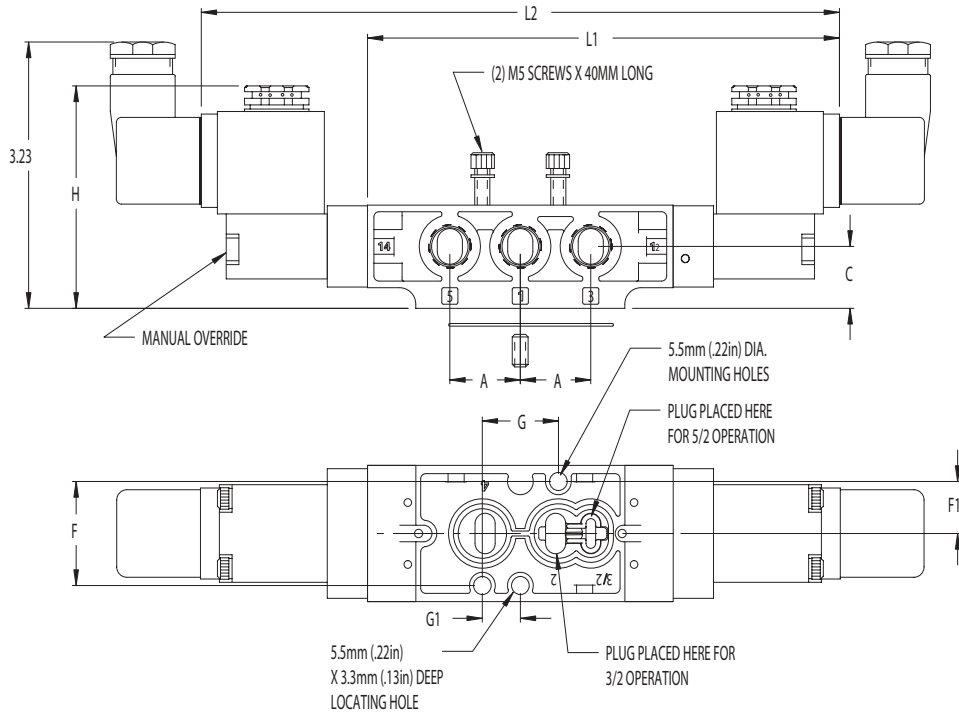
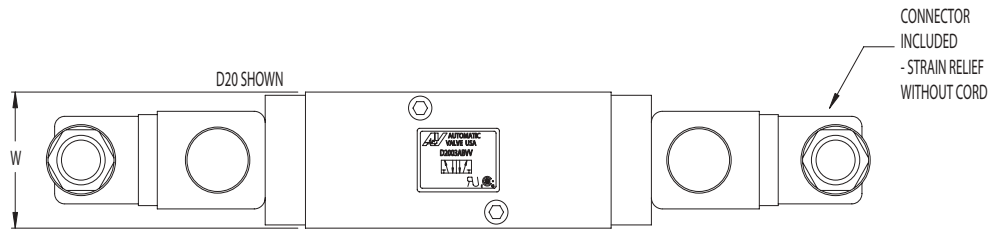
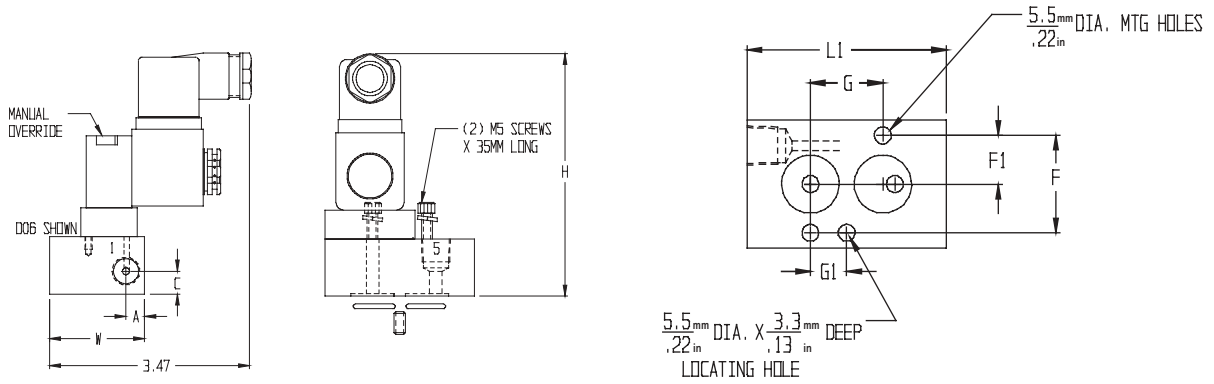
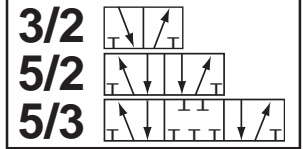

SERIES	DESCRIPTION	A	C	F	F1	G	G1	H	L1	L2	W
D06	SINGLE SOLENOID	8,4 .33	10,2 .40	32,0 1.26	16,0 .63	23,9 .94	11,9 .47	107,2 4.22	66,0 2.60	-	41,9 1.65
D20	SINGLE SOLENOID	22,2 .88	19,1 .75	32,0 1.26	16,0 .63	23,9 .94	11,9 .47	68,3 2.69	149 5.86	-	41,9 1.65
	DOUBLE SOLENOID	22,2 .88	19,1 .75	32,0 1.26	16,0 .63	23,9 .94	11,9 .47	68,3 2.69	-	201 7.92	41,9 1.65

Units of Measure: Top - mm, Bottom - inches

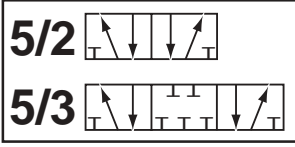

AIR PILOT MODELS



LEFT



RIGHT

**D20
SINGLE**



**D20
DOUBLE**

MODEL NUMBERS

FUNCTION		PORT SIZE	Cv (l/min)	MODEL NUMBER	BODY MATERIAL	SEAL MATERIAL	Kg (LB)
DESCRIPTION	SCHEMATIC						
5/2 SINGLE LEFT		1/4	1.8 (1770)	D2003ACAR	ALUMINUM	NBR	0,32 (.70)
5/2 SINGLE RIGHT				D2003AAAR			
5/2 DOUBLE				D2003ABAA			
5/3 BLOCK DOUBLE		1/4	1.8 (1770)	D2003CBADA	ALUMINUM	NBR	0,36 (.80)
5/3 EXHAUST DOUBLE				D2003DBADA			
5/3 PRESSURE DOUBLE				D2003EBADA			

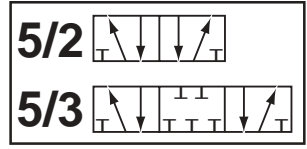

DIMENSIONAL INFORMATION

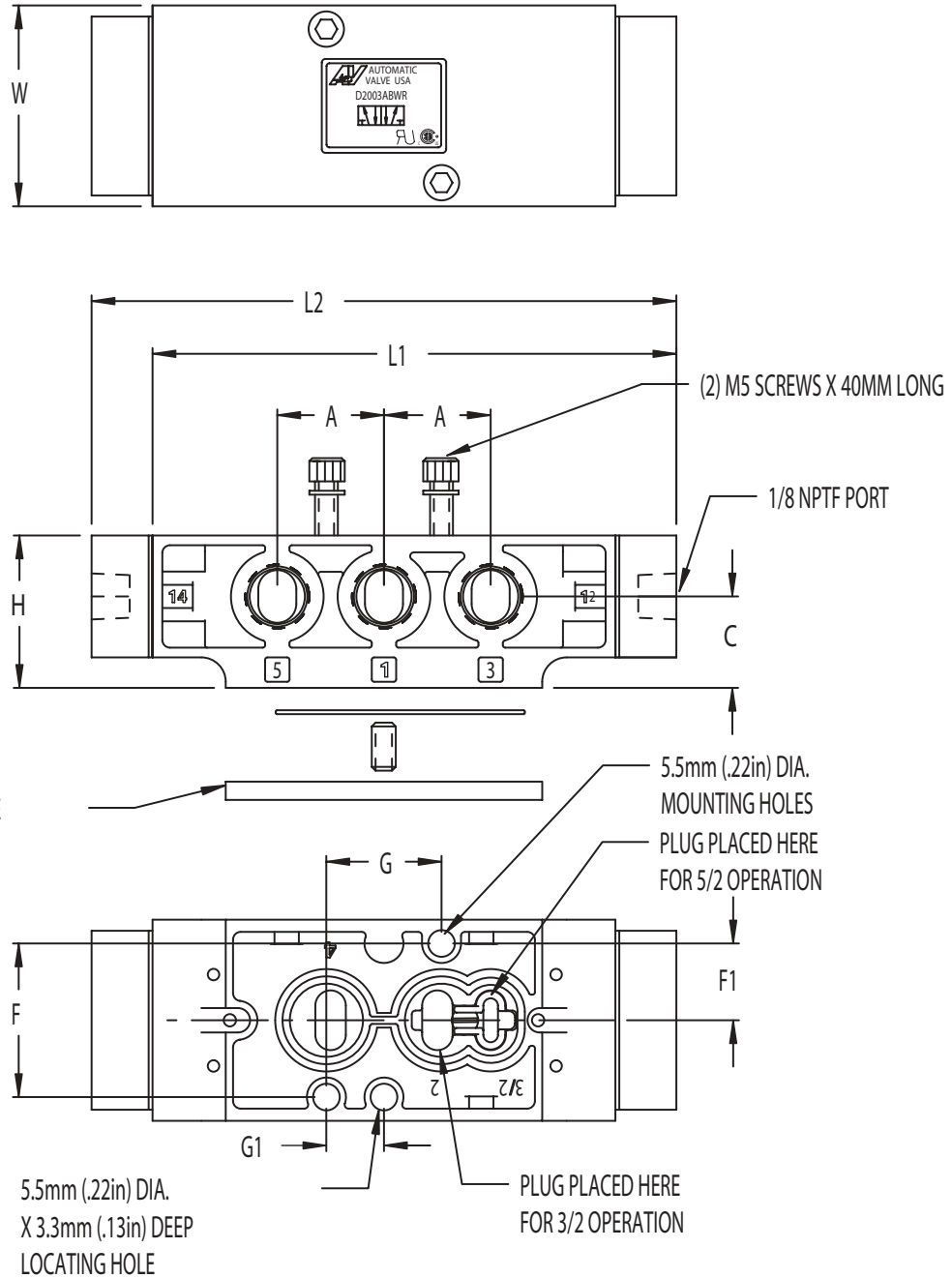

SERIES	DESCRIPTION	A	C	F	F1	G	G1	H	L1	L2	W
D20	SINGLE AIR PILOT	22,2 .88	19,1 .75	32,0 1.26	16,0 .63	23,9 .94	11,9 .47	31,7 1.25	109 4.30	-	41,9 1.65
	DOUBLE AIR PILOT	22,2 .88	19,1 .75	32,0 1.26	16,0 .63	23,9 .94	11,9 .47	31,7 1.25	-	122 4.80	41,9 1.65

Units of Measure: Top - mm, Bottom - inches

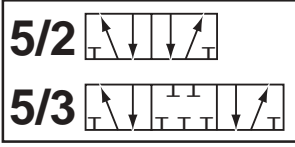

OPTIONS

(LISTED AT THE END OF THE MODEL NUMBER IN ALPHA-NUMERIC ORDER)

A - FLUOROELASTOMER SEALS

For applications where fluid media or ambient conditions are not compatible with nitrile seals.
 Note: Fluorocarbon seals do not increase the effective temperature range of the valve.
 For high temperature applications, consult the factory.

B - EXTERNAL PILOT

For solenoid applications when the pressure to port one is less than 35 PSIG (2 BAR). See example below for field conversion.

FIELD CONVERSION

- Remove solenoid and cap from valve body.
- Rotate gasket 180 degrees so that the internal pilot hole in the valve body is covered by the gasket.
- Reassemble the gasket, cap and solenoid to the valve body. Make sure gasket completely covers internal pilot hole before tightening screws.
- Remove the 1/8 NPTF pipe plug from the cap and make the external pilot connection.

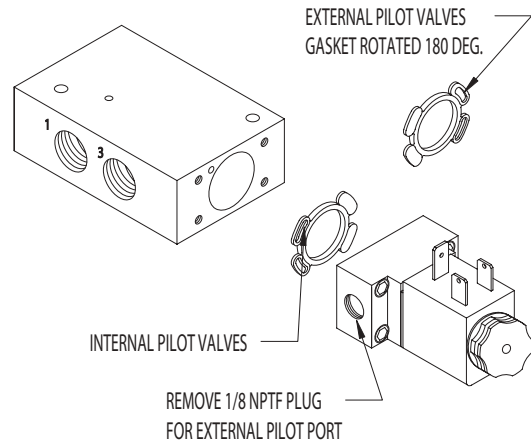

C - CONDUIT COIL

Refer to Electrical Section for details.

CT - CONDUIT COIL HIGH TEMPERATURE

Refer to Electrical Section for details.

D - DUSTPROOF

For applications in extremely dusty and contaminated environments. Standard vent ports are plugged. Operators breathe through the exhaust ports via flats on the end of the spools.

G - COIL WITH 18" LEADS

Refer to Electrical Section for details.

P - TRANSITION PLATE

For mounts to surfaces smaller than 2 1/2" x 1 3/8". Refer to next page for Installation Instructions.

Q - CLOSED LOOP

S - STAINLESS STEEL

Stainless steel body, all other external parts corrosive resistant; for corrosive environment applications.

SS - 316 STAINLESS STEEL

Stainless steel body, all other external parts corrosive resistant; for corrosive environment applications.

W - G THREADS

Y - EXPLOSION-PROOF COIL (CSA, FM)

Refer to Electrical Section for details.

Z - EXPLOSION-PROOF COIL (ATEX, PTB)

Refer to Electrical Section for details.

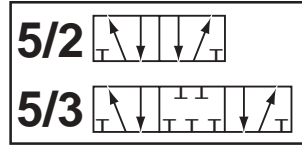

TRANSITION PLATE

Part Number A8021-339

Installation Instructions

This plate is designed for use in situations where the NAMUR solenoid valve needs to be raised above the mounting surface or where the sealing face of the solenoid valve extends beyond the mounting surface.

(The minimum required mounting area measures 2 1/2" x 1 3/8")

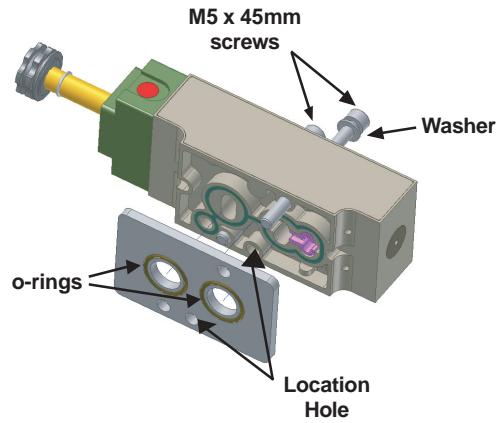

MOUNTING SURFACE

Installation

1. Place the plate between the solenoid valve and the mounting surface.
2. Use the supplied M5 x 45mm screws to secure the solenoid valve/plate assembly to the mounting surface. DO NOT use the solenoid valve screws (they are too short to engage correctly).
3. Note: The o-ring face of the plate must seal on the mounting surface. The gasket on the solenoid valve will seal on flat surface of the plate.
4. Orientation of the plate is universal (but keep the o-rings against the mounting surface). Location holes must be aligned.
5. Washers on the supplied screws should be retained between the screw head and the top of the solenoid.

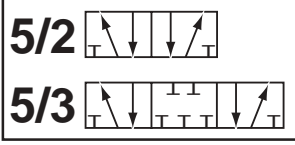

ELECTRICAL INFORMATION

DESCRIPTION		WHEN THE 8TH CHARACTER OF MODEL NUMBER IS:	INSTRUCTIONS	COIL PART NUMBER ** = VOLTAGE
NEMA 4X WITH DIN 43650 CONNECTION		W	Order coil separately (specify voltage code from below)	7019-9**
NEMA 4X WITH 18" LEADS		W	Order coil separately (specify voltage code from below)	7019-9**G
NEMA 4X 1/2" CONDUIT WITH 30" LEADS		W	Order coil separately (specify voltage code from below)	7019-9**C 7019-9**CT (high temperature 82°C maximum)
EXPLOSION-PROOF 1/2" CONDUIT WITH 24" LEADS [CSA 202633X FM APPROVED CL. I; ZONE1Ex m II T4; AEx m II CL. I; Div. 1; GR. A, B, C, D CL. II; GR. E, F, G CL. III T4 Ta= -20°C to +60°C NEMA: 4, 4X, 7C, 7D]		W	Order coil separately (specify voltage code from below)	7019-9**Y
INTRINSICALLY-SAFE WITH STRAIN RELIEF (EEx ia IICT6) CL. I; Div. 1; GR. A, B, C, D CL. II; GR. E, F, G CL. III; Div. 1 Hazardous Location		V	Coil and Connector included with valve (24VDC only)	A7106-374
EXPLOSION-PROOF WITH 3m CABLE AND STRAIN RELIEF (Ex II 2G EExm II T - I EC Exm II T-)		Z	Order coil separately (specify voltage code from below)	7152-9**

VOLTAGE +/- 10 %	** C O D E	CURRENT (AMPS)								RESISTANCE (OHMS @ 25° C)				POWER (AC = VA DC = WATTS)			
		INRUSH				HOLDING				NEMA							
		4	7	V	Z	4	7	V	Z	4	7	V	Z	4	7	V	Z
22/50 24/60	DA	.40	.55	-	-	.40	.32	-	-	31	19	-	-	4.8	4.5	-	-
110/50 120/60	AA	.08	.096	-	-	.06	.054	-	.029	840	530	-	1164	4.8	6.5	-	3.0
220/50 240/60	AB	.04	.048	-	-	.03	.027	-	.015	3400	2345	-	6730	6.0	6.5	-	3.0
12 VDC	DA	.40	-	-	-	.40	.375	-	.267	31	32	-	45	4.8	7	-	3.5
24 VDC	DB	.20	-	.03	.136	.20	.187	.03	.136	121	128	275	177	4.8	-	2.1	3.5
24 VDC	DBL	-	-	-	-	-	-	-	-	320	-	-	-	1.8	4.5	-	-
125 VDC	AB	.04	-	-	-	.04	.06	-	-	3400	2000	-	-	4.8	7	-	-

For alternative lower wattage options, please consult the factory.

DIN 43650 CONNECTORS						
TYPE	STRAIN RELIEF WITHOUT CORD	1/2" CONDUIT WITHOUT CORD	MOLDED WITH 6' CORD	STRAIN RELIEF WITH LIGHT		STRAIN RELIEF WITH LIGHT + 6' CORD
				100-240 AC 48-120 DC	6-48 AC/DC	100-240 AC 48-120 DC
PART NUMBER	7020-001	7039-001	7020-006	7020-AA	7020-DB	7094-006
						6-48 AC/DC
						7094-007

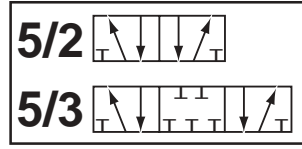

SERVICE KIT INFORMATION

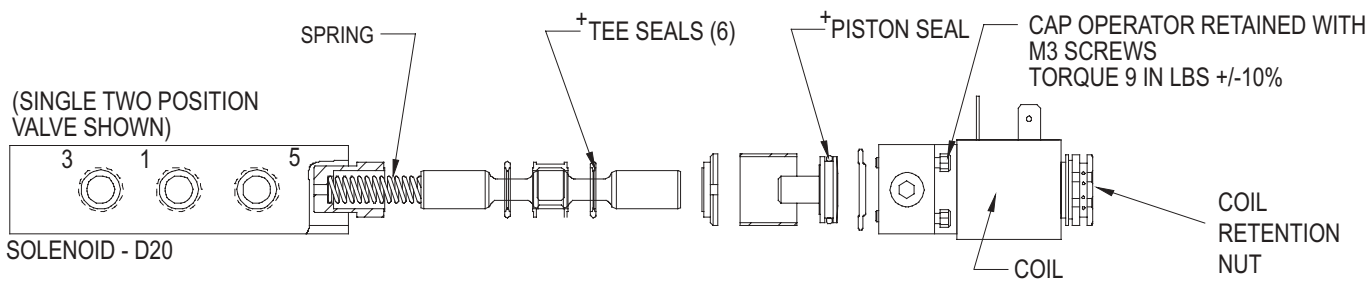

SERVICE KIT INSTALLATION

1. Remove Coil retention nut.
2. Remove Coil.
3. Remove screws from cap of operator.
4. Remove cap.
5. Remove existing serviceable components.
6. Replace with kit components. **+All seals must be lubricated with Magnalube-G or equivalent.**
7. Align pilot hole in body with pilot hole in cap.
8. Torque screws as shown above.

Lubrication of Automatic Valve products is not required but is recommended to maximize service life. Oils should be compatible with seal material, have an ISO 32 or lighter viscosity, and have an aniline point between 82°C (180°F) and 99°C (210°F). Refer to Maintenance section of catalog for recommended lubricants.

MODEL NUMBERS

SERIES	FUNCTION			
	SINGLE		DOUBLE	
	PART NUMBER	CONTENTS	PART NUMBER	CONTENTS
D20	K-L20-SGL K-L20-SGL-A (Fluoroelastomer)	Tee Seals (6) Piston Seal (1) Spring (1)	K-L20-DBL K-L20-DBL-A (Fluoroelastomer)	Tee Seals (6) Piston Seal (2)
	K-D20- MTG		Plug Assembly (1) Gasket (1) Screws (2) Set screw (1) Washers (2)	

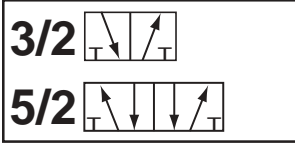

4 WAY / 3 WAY CONVERSION

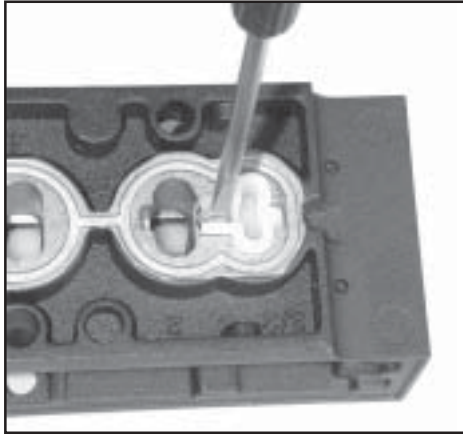

Step 1. Using a 3mm screwdriver loosen the plug retention screw.

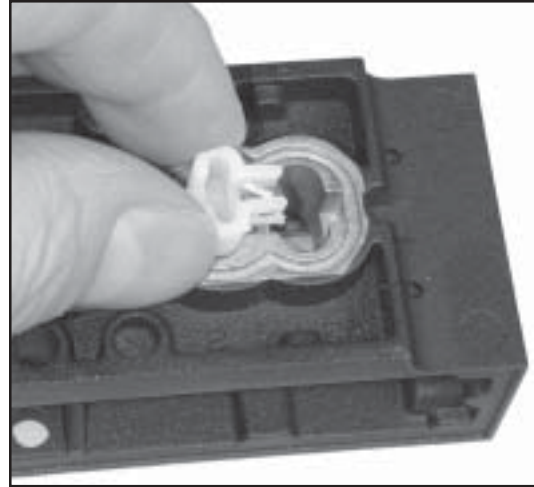

Step 2. Remove the plug, lightly lubricate plug o-ring, and place in adjacent cavity.

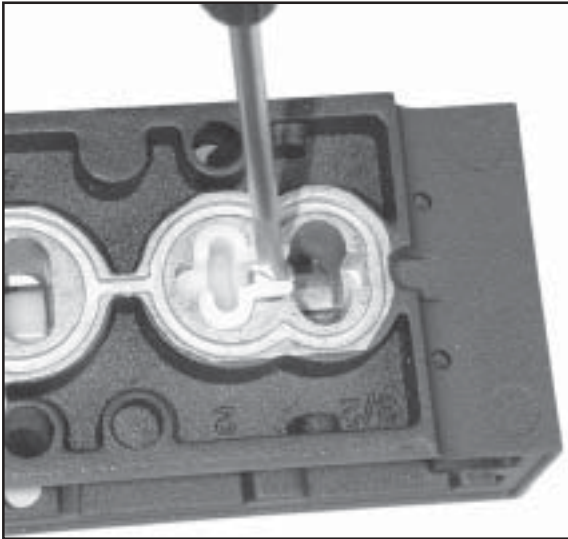

Step 3. Tighten plug retention screw to 6 +/- 10%in lbs.

Separate kits containing 10 plugs are available.

SERIES	PART NUMBER	CONTENTS
D20	K-D20-PLUG	Plug Assemblies (10) (screw/seal/plug)



NOTES



NOTES